

ALUMATANK

Vacuum Pumper Tanks

Capacity: 2000, 2500, 2800, 3600, 4200 & 5000 gallon capacity tanks available.

Optional: Multi-compartment tanks.

Heads: 54", 60", 66", 71" & 81" diameters

Standard Features & Specifications:

1/4" 5454 polished aluminum

Aluminum reinforcing rings

Aluminum full dish anti-surge baffles

20" NVE Manway top of tank & rear head

31" Wide hose trays full length both sides

4" Inlet front and rear

6" Rear discharge with large box sump

NVE Low profile primary shut-off

(3) 5" Sight glasses

Ladder with non-slip steps

Lifting hooks top of tank

(2) Halogen 'swivel' work lights on rear head

Betts 'Snap-Seal' L.E.D. vapor proof lights

Oversized flat hose hooks on rear head

Heavy duty rear bumper with aluminum cover

Five year 'No Leak' tank warranty

Single and tandem axle cabs & chassis.

Available with front lift & rear opening door.

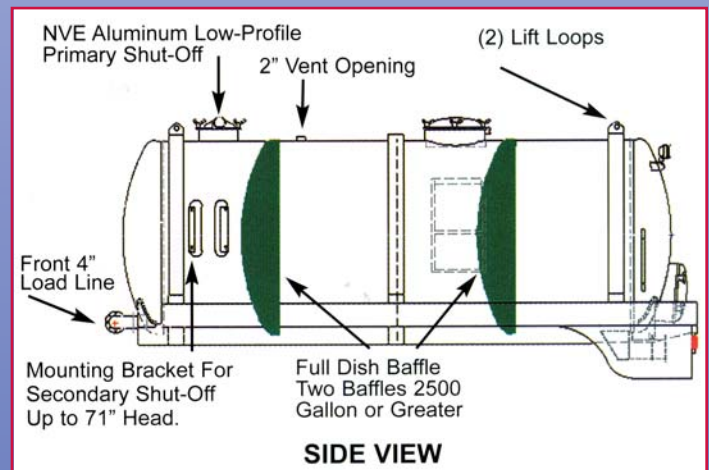
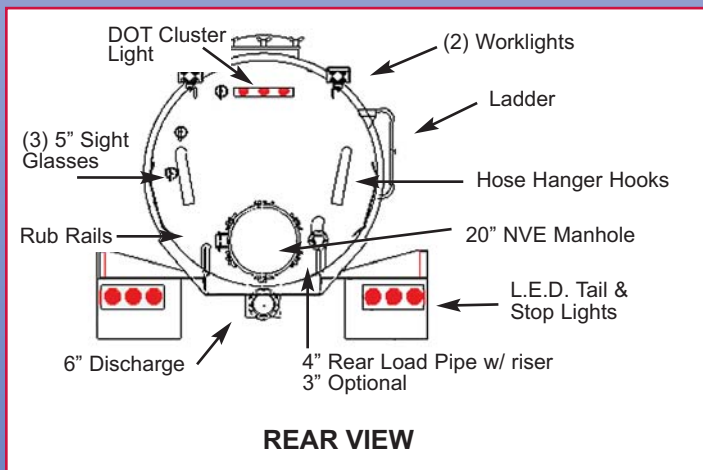

progress tank

steel, aluminum & stainless steel... since 1922

Exclusively available through authorized Progress Tank distributors www.progress-tank.com

